

BUEIRO SIMPLES TUBULAR DE CONCRETO - BOCAS NORMAIS E ESCONSAS (II)

PLANTA NORMAL

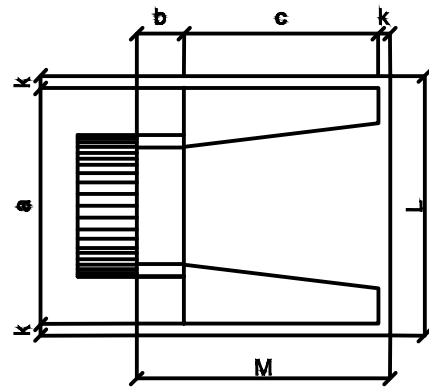

VISTA LATERAL

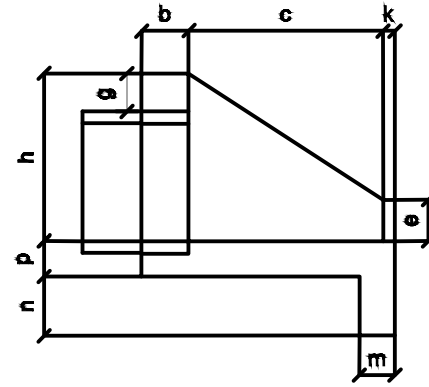

VISTA FRONTAL

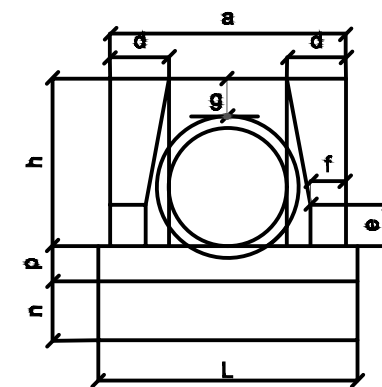

PLANTA ESCONSO

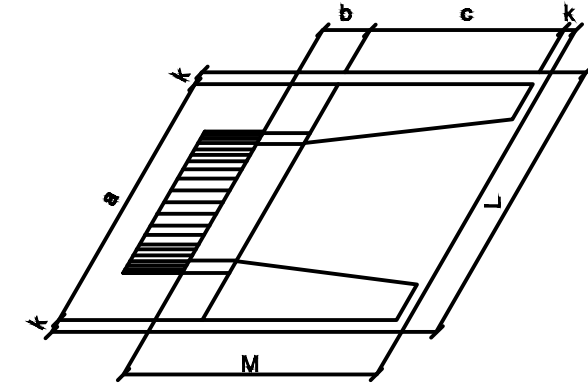

DIMENSÕES E CONSUMOS MÉDIOS PARA UMA UNIDADE

Esc.	BUEIRO SIMPLES TUBULAR $\Phi = 40$													formas m ²	con creto m ³	cimento saco 50kg	areia m ³	brita 1 brita 2 m ³	água m ³	madeira m ³
	a	b	c	d	e	f	g	h	k	m	n	p	L							
0°	80			20									90	2,29	0,423	2,072	0,288	0,313	0,068	0,057
5°	80			20									90	2,30	0,423	2,072	0,288	0,313	0,068	0,057
10°	81			20									91	2,31	0,423	2,073	0,288	0,313	0,068	0,058
15°	83			21									93	2,33	0,423	2,074	0,288	0,313	0,068	0,058
20°	85	20	90	21	15	10	20	66	5	20	20	20	96	2,36	0,424	2,076	0,288	0,314	0,068	0,059
25°	88			22									99	2,41	0,424	2,078	0,288	0,314	0,068	0,060
30°	92			23									104	2,47	0,425	2,081	0,289	0,314	0,068	0,062
35°	98			24									110	2,56	0,425	2,084	0,289	0,315	0,068	0,064
40°	104			26									117	2,67	0,426	2,088	0,290	0,315	0,068	0,067
45°	113			28									127	2,84	0,427	2,092	0,290	0,316	0,068	0,071

Esc.	BUEIRO SIMPLES TUBULAR $\Phi = 100$													formas m ²	con creto m ³	cimento saco 50kg	areia m ³	brita 1 brita 2 m ³	água m ³	madeira m ³
	a	b	c	d	e	f	g	h	k	m	n	p	L							
0°	170			35									190	9,68	2,514	12,318	1,709	1,860	0,402	0,242
5°	171			35									191	9,69	2,514	12,320	1,710	1,861	0,402	0,242
10°	173			36									193	9,75	2,515	12,325	1,710	1,861	0,402	0,244
15°	176			36									197	9,85	2,517	12,334	1,712	1,863	0,403	0,246
20°	181	30	165	37	50	20	30	142	10	27	37	27	202	9,99	2,520	12,346	1,713	1,865	0,403	0,250
25°	188			39									210	10,19	2,523	12,362	1,716	1,867	0,404	0,255
30°	196			40									219	10,47	2,527	12,381	1,718	1,870	0,404	0,262
35°	208			43									232	10,84	2,531	12,403	1,721	1,873	0,405	0,271
40°	222			46									248	10,36	2,536	12,427	1,725	1,877	0,406	0,284
45°	240			49									269	12,07	2,542	12,455	1,728	1,881	0,407	0,302

Esc.	BUEIRO SIMPLES TUBULAR $\Phi = 60$													formas m ²	con creto m ³	cimento saco 50kg	areia m ³	brita 1 brita 2 m ³	água m ³	madeira m ³
	a	b	c	d	e	f	g	h	k	m	n	p	L							
0°	110			25									130	4,17	0,932	4,567	0,634	0,690	0,149	0,104
5°	110			25									130	4,18	0,932	4,568	0,634	0,690	0,149	0,104
10°	112			25									132	4,20	0,933	4,570	0,634	0,690	0,149	0,105
15°	114			26									135	4,24	0,933	4,573	0,635	0,691	0,149	0,106
20°	117	20	125	27	25	10	30	88	10	23	33	23	138	4,30	0,934	4,577	0,635	0,691	0,149	0,107
25°	121			28									143	4,38	0,935	4,583	0,636	0,692	0,150	0,110
30°	127			29									150	4,49	0,937	4,589	0,637	0,693	0,150	0,112
35°	134			31									159	4,65	0,938	4,597	0,638	0,694	0,150	0,116
40°	144			33									170	4,85	0,940	4,605	0,639	0,695	0,150	0,121
45°	156			35									184	5,14	0,942	4,615	0,640	0,697	0,151	0,129

Esc.	BUEIRO SIMPLES TUBULAR $\Phi = 120$													formas m ²	con creto m ³	cimento saco 50kg	areia m ³	brita 1 brita 2 m ³	água m ³	madeira m ³
	a	b	c	d	e	f	g	h	k	m	n	p	L							
0°	200			40									220	12,61	3,638	17,825	2,474	2,692	0,582	0,315
5°	201			40									221	12,64	3,639	17,830	2,474	2,693	0,582	0,316
10°	203			41									223	12,71	3,642	17,844	2,476	2,695	0,583	0,318
15°	207			41									228	12,84	3,646	17,866	2,479	2,698	0,583	0,321
20°	213	40	180	43	60	25	30	163	10	28	38	28	234	13,03	3,653	17,898	2,484	2,703	0,584	0,326
25°	221			44									243	13,30	3,661	17,937	2,489	2,709	0,586	0,332
30°	231			46									254	13,67	3,671	17,986	2,496	2,716	0,587	0,342
35°	244			49									269	14,16	3,682	18,042	2,504	2,725	0,589	0,354
40°	261			52									287	14,85	3,695	18,105	2,513	2,734	0,591	0,371
45°	283			57									311	15,79	3,709	18,176	2,522	2,745	0,593	0,395

Esc.	BUEIRO SIMPLES TUBULAR $\Phi = 80$													formas m ²	con creto m ³	cimento saco 50kg	areia m ³	brita 1 brita 2 m ³	água m ³	madeira m ³
	a	b	c	d	e	f	g	h	k	m	n	p	L							
0°	140			30									160	6,83	1,619	7,932	1,101	1,198	0,259	0,171
5°	141			30									161	6,85	1,619	7,934	1,101	1,198	0,259	0,171
10°	142			30									162	6,88	1,620	7,937	1,101	1,199	0,259	0,172
15°	145			31									166	6,95	1,621	7,942	1,102	1,199	0,259	0,174
20°	149	25	145	32	35	15	30	120	10	25	35	25	170	7,06	1,622	7,950	1,103	1,201	0,260	0,176
25°	154			33									177	7,20	1,624	7,960	1,105	1,202	0,260	0,180
30°	162			35									185	7,39	1,627	7,971	1,106	1,204	0,260	0,185
35°	171			37									195	7,66	1,630	7,985	1,108	1,206	0,261	0,191
40°	183			39									209	8,02	1,633	8,000	1,110	1,208	0,261	0,201
45°	198			42									226	8,52	1,636	8,017	1,113	1,211	0,262	0,213

Esc.	BUEIRO SIMPLES TUBULAR $\Phi = 150$													formas m ²	con creto m ³	cimento saco 50kg	areia m ³	brita 1 brita 2 m ³	água m ³	madeira m ³
	a	b	c	d	e	f	g	h	k	m	n	p	L							
0°	240			45									260	20,39	6,487	31,784	4,411	4,800	1,038	0,510
5°	241			45									261	20,43	6,488	31,791	4,412	4,801	1,038	0,511
10°	244			46									264	20,53	6,492	31,810	4,414	4,804	1,039	0,513
15°	248			47									269	20,71	6,499	31,843	4,419	4,809	1,040	0,518
20°	255	50	260	48	75	30	30	194	10	29	39	29	277	20,98	6,508	31,888	4,425	4,816	1,041	0,524
25°	265			50									287	21,35	6,520	31,946	4,433	4,824	1,043	0,534
30°	277			52									300	21,86	6,534	32,015	4,443	4,835	1,045	0,547
35°	293			55									317	22,56	6,550	32,096	4,454	4,847	1,048	0,564
40°	313			59									339	23,51	6,569	32,188	4,467	4,861	1,051	0,588
45°	339			64									368	24,84	6,590	32,290	4,481	4,876	1,054	0,621

NOTA:

1 - Bueiros com diâmetro de 40cm e de 60cm apresentam limitações à limpeza.
No entanto, por serem largamente utilizados, são apresentados neste Álbum.



PREFEITURA MUNICIPAL DE ROCA SALES



OLHANDO PARA O FUTURO
GESTÃO 2025 - 2028

TIPO: IMPLANTAÇÃO + PAVIMENTAÇÃO COM CBUQ

DRENAGEM
DETALHAMENTOS

LOCAL: ESTRADA GERAL DA LINHA MARECHAL DEODORO

TRECHO:

ÁREA:

PROPRIETÁRIO:

PREFEITURA MUNICIPAL DE ROCA SALES
PREFEITO JONES WUNSCH

RESPONSÁVEL TÉCNICO:

ENG. CIVIL JAIRO MARASCA
CREA RS-260685

DATA:

09/2025

ESCALA:

FRANCHA:

DET-2